

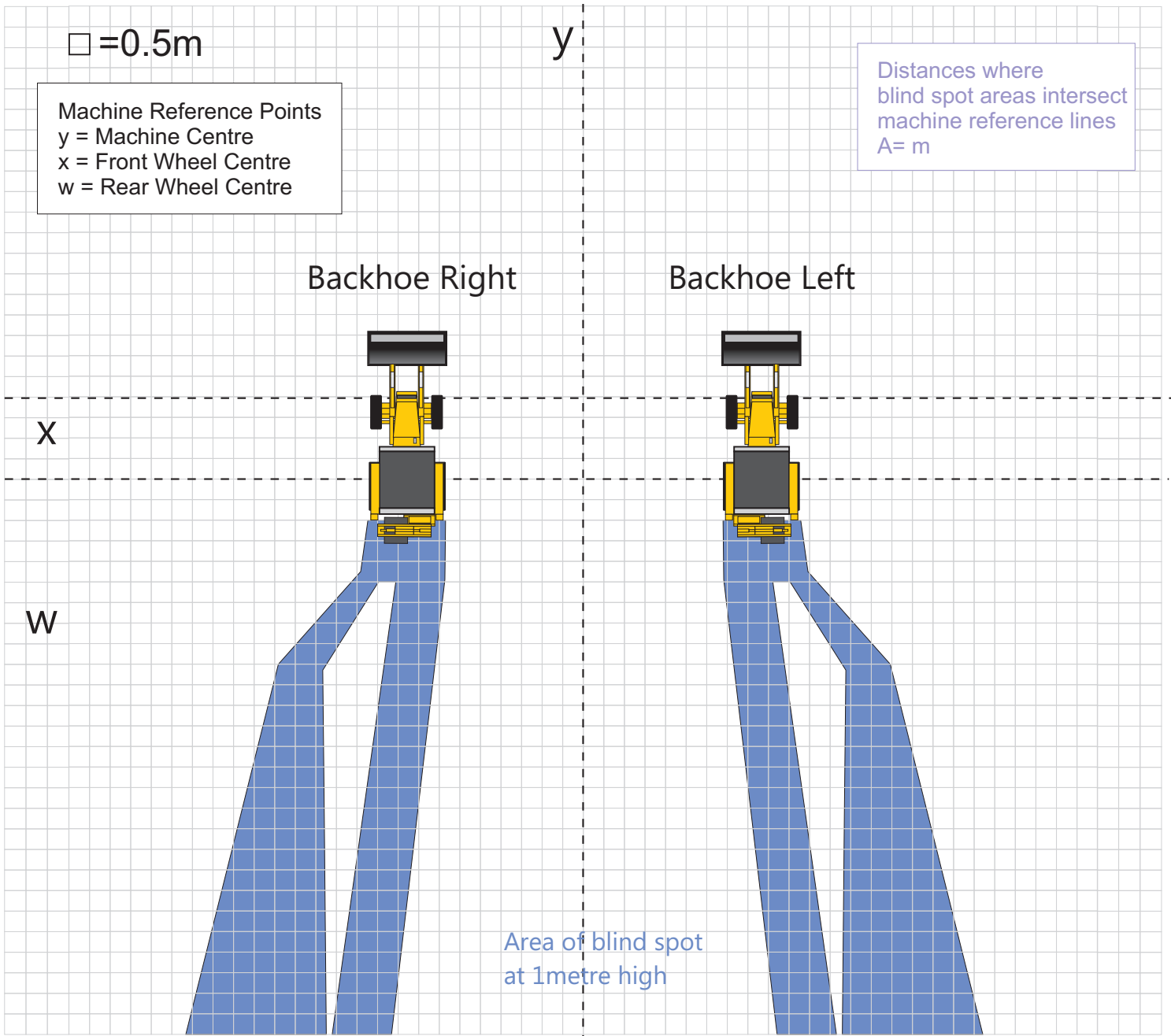

JCB 2CX Streetmaster

# Machine Visibility





JCB 2CX Streetmaster

# Enhanced Visibility

□ = 0.5m

Machine Reference Points  
 y = Machine Centre  
 x = Front Wheel Centre  
 w = Rear Wheel Centre

### Backhoe Right

### Backhoe Left

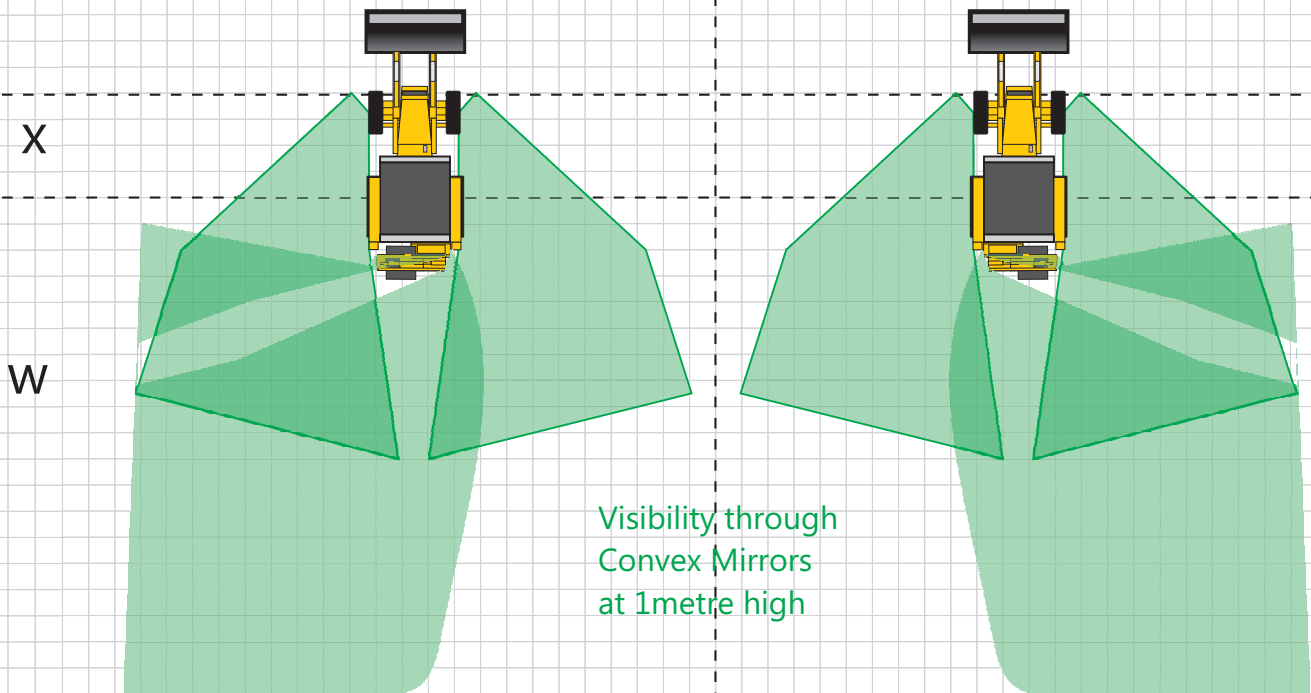

Visibility through Convex Mirrors at 1metre high



- 2 x Fang 1/4 convex wing mirrors
- 2 x BMC54 2cx mounting bracket
- 2 x Nc100 convex mirror - Mounted Rear Rhs&Lhs
- 2 x BMC175 - 20" 35° bend mounting arm
- 2 x BML139 - Plastic fixing bracket
- Optional
- 1 x FLT092 Interior convex mirror





JCB 2CX Streetmaster

# Machine Visibility

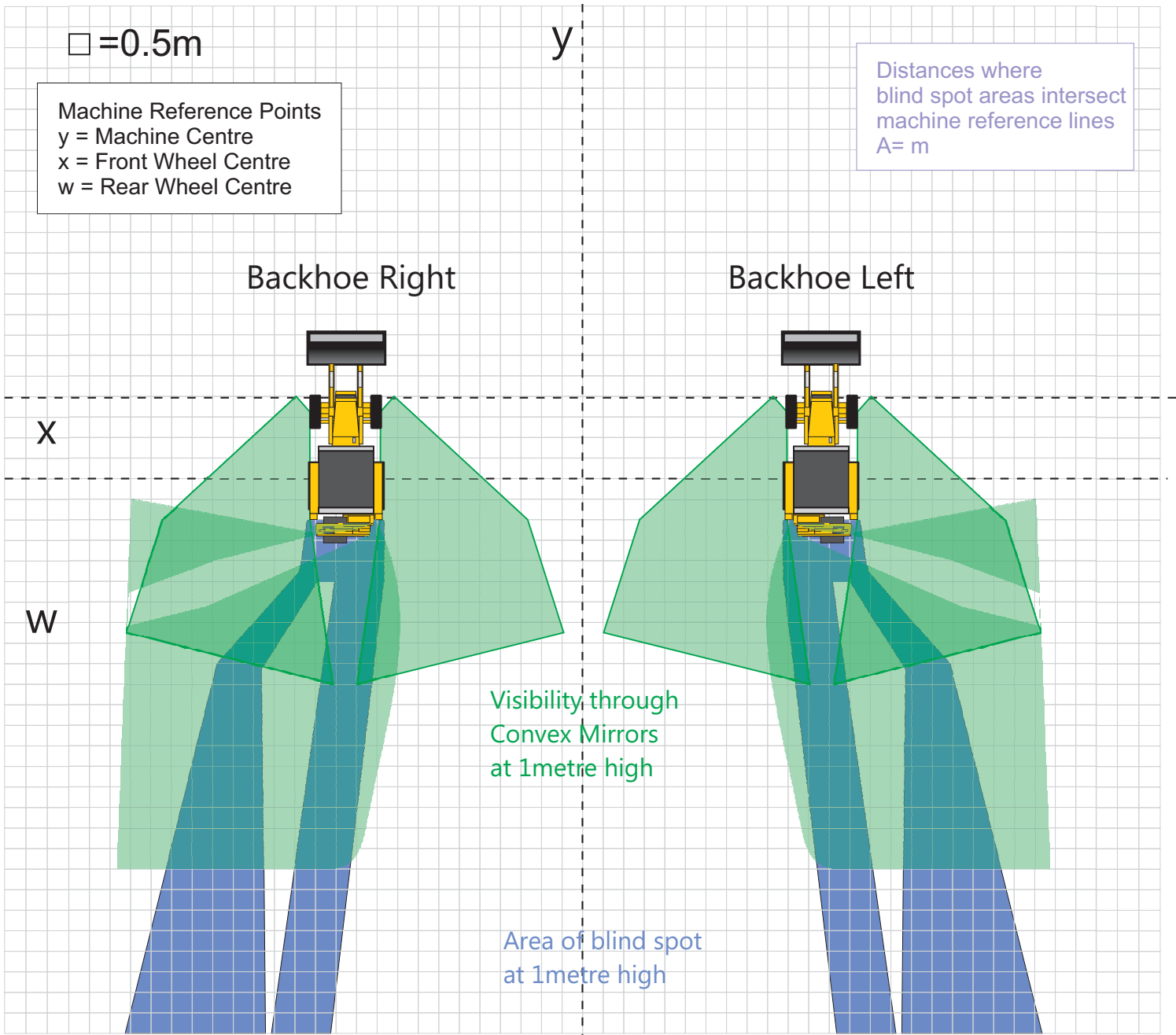

- 2 x Fang 1/4 convex wing mirrors
- 2 x BMC54 2cx mounting bracket
- 2 x Nc100 convex mirror - Mounted Rear Rhs&Lhs
- 2 x BMC175 - 20" 35° bend mounting arm
- 2 x BML139 - Plastic fixing bracket
- Optional
- 1 x FLT092 Interior convex mirror

