

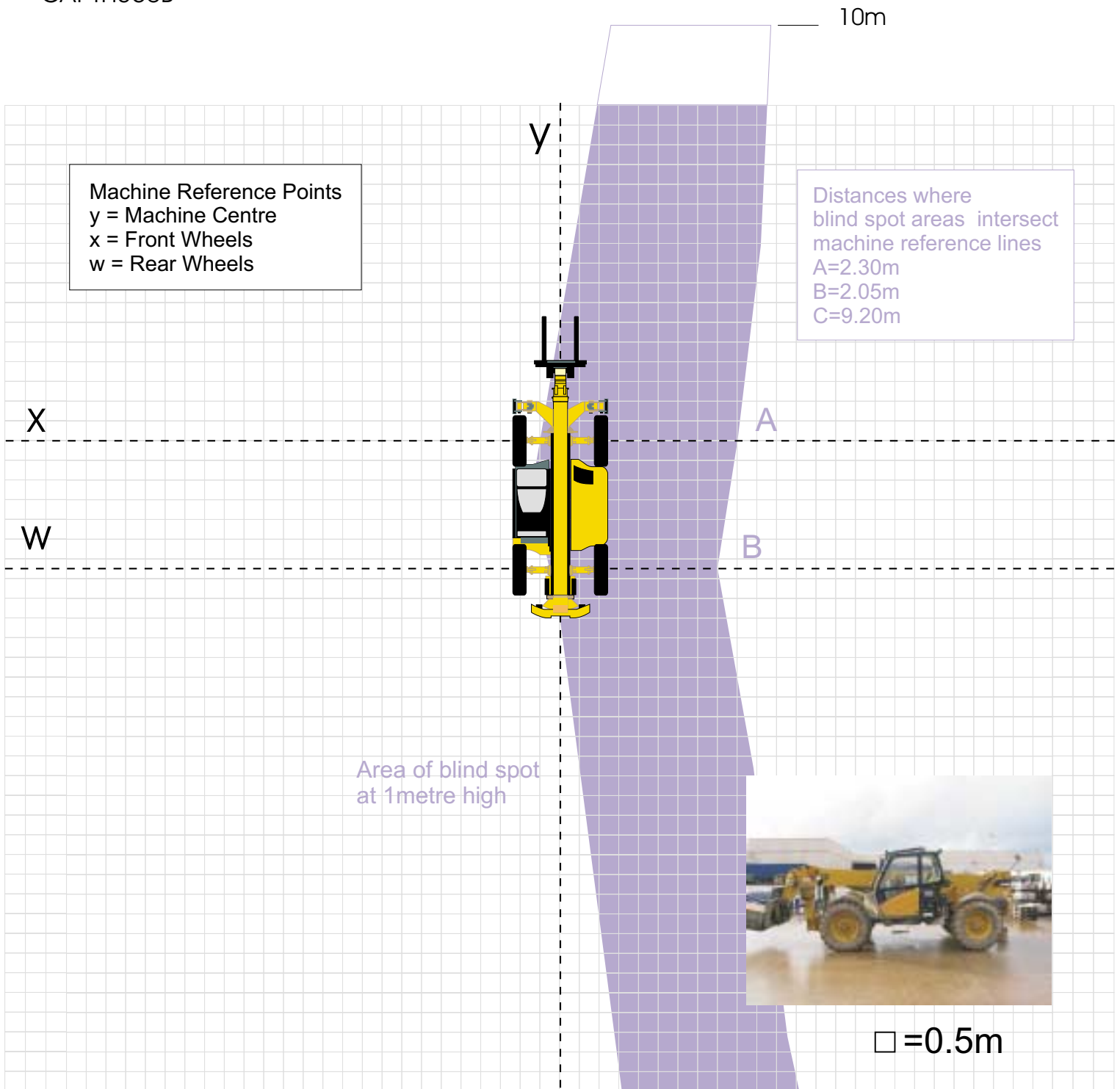

CAT TH360B

Comparison

carriage 500mm





CAT TH360B

Machine Vision

carriage 500mm

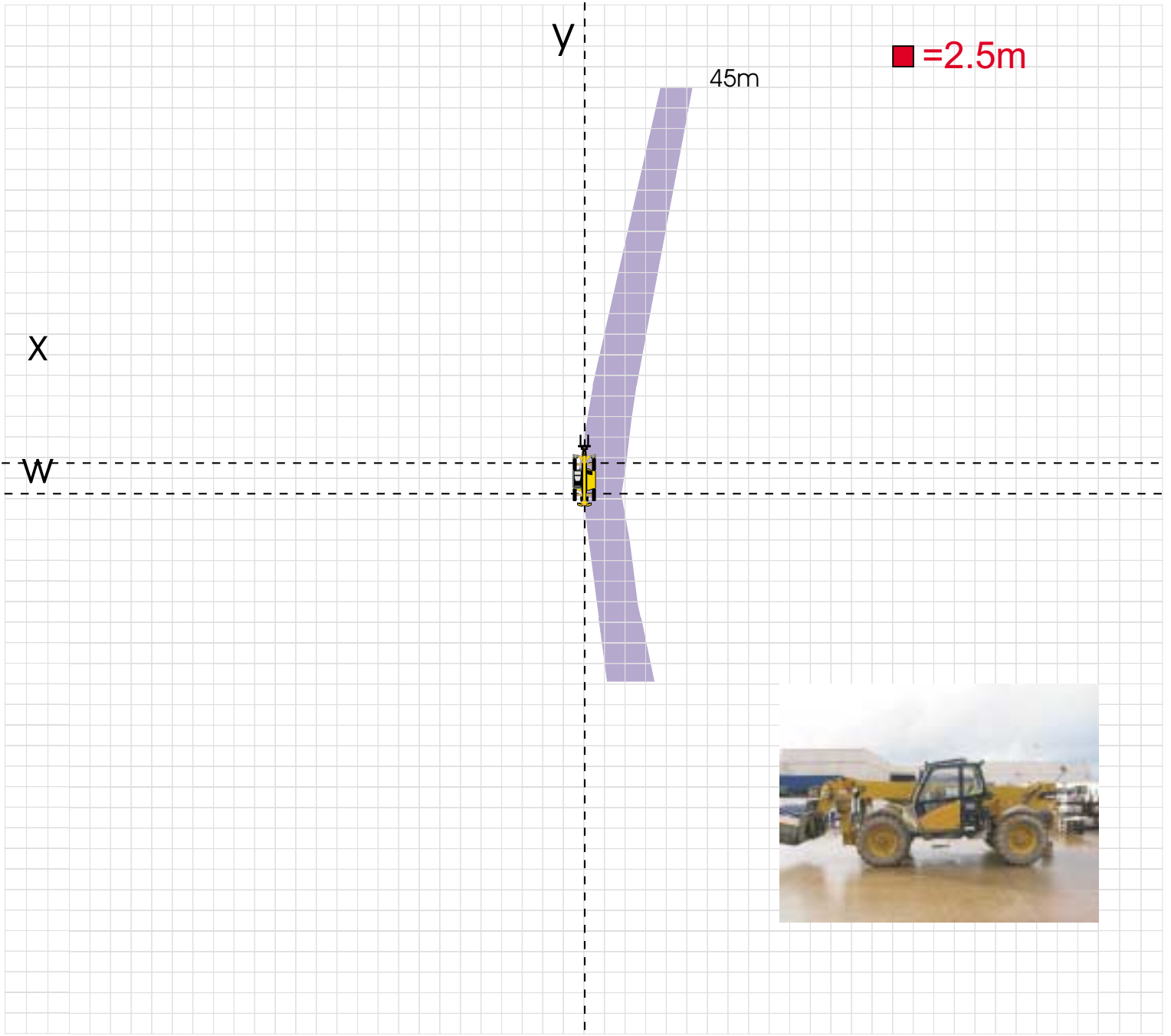



CAT TH360B

Enhanced Vision

carriage 500mm

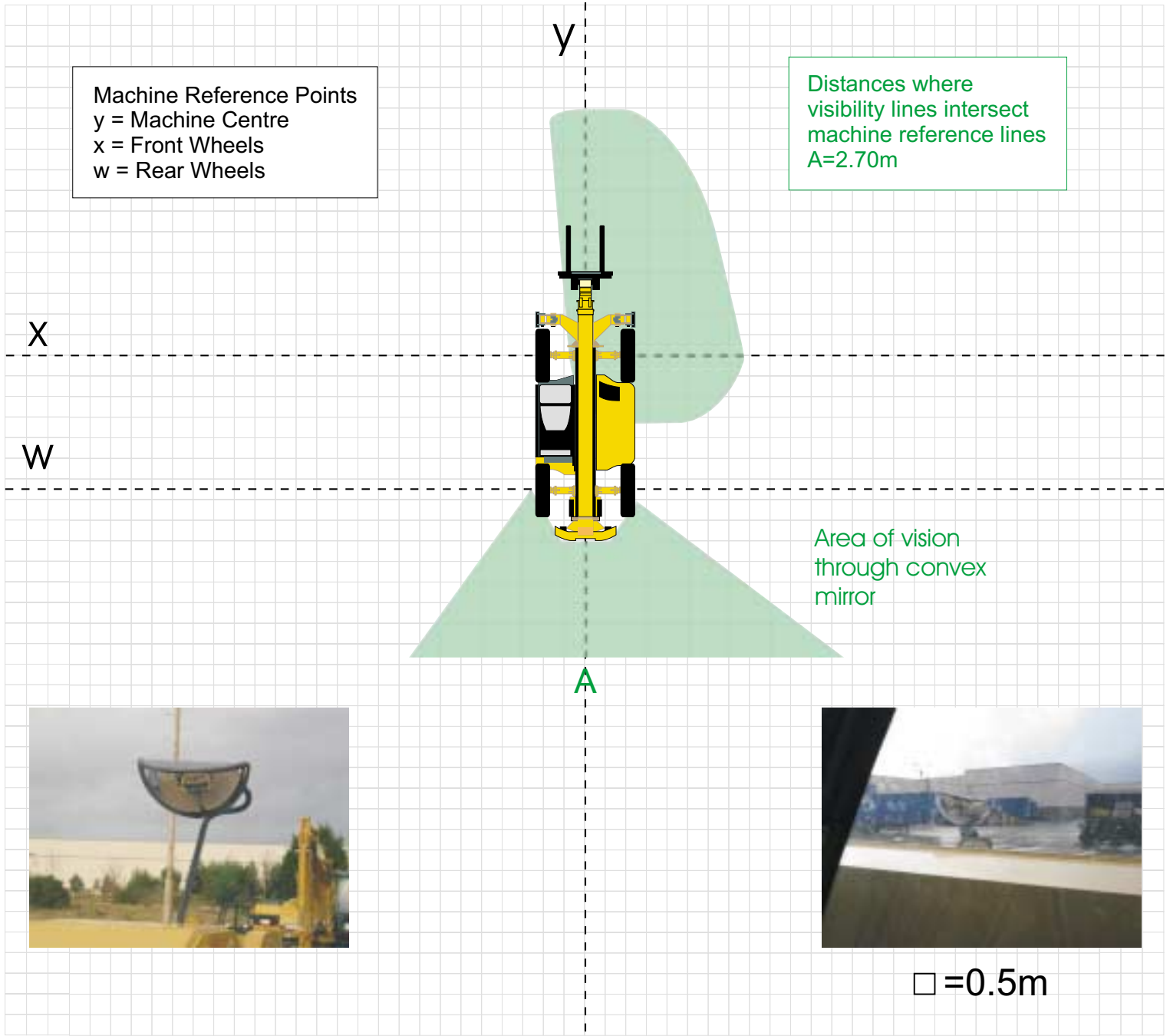



CAT TH360B

Comparison

carriage 500mm

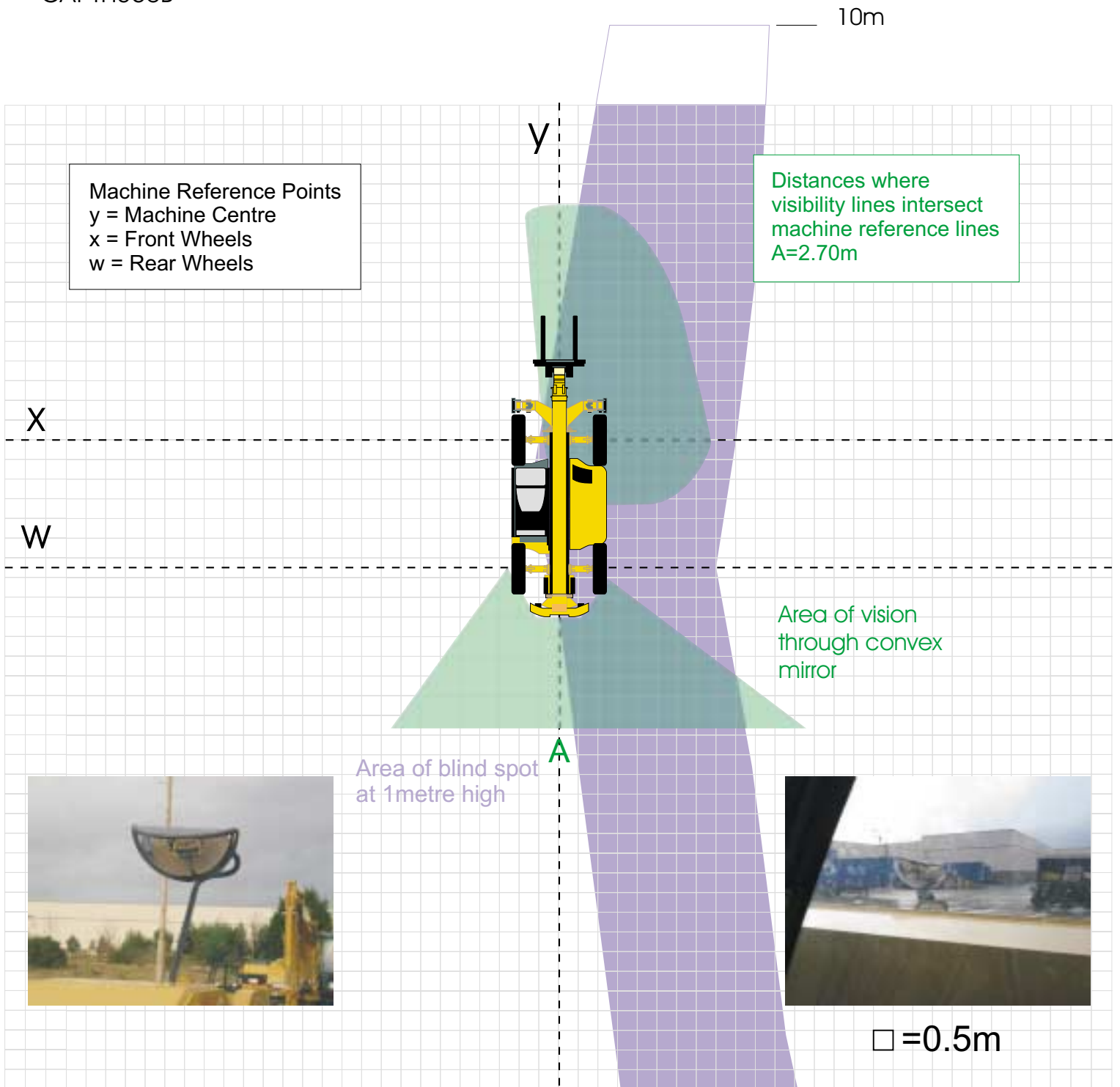

Convex Mirrors TH Fitting Details

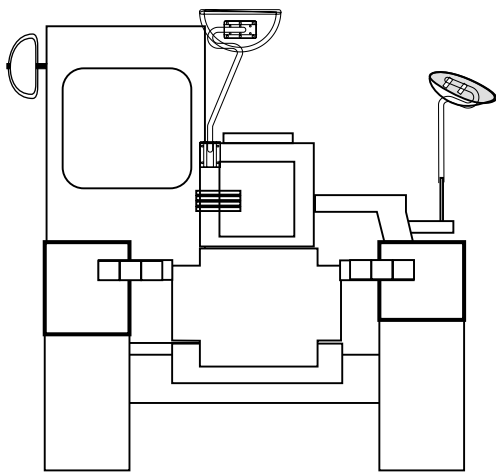
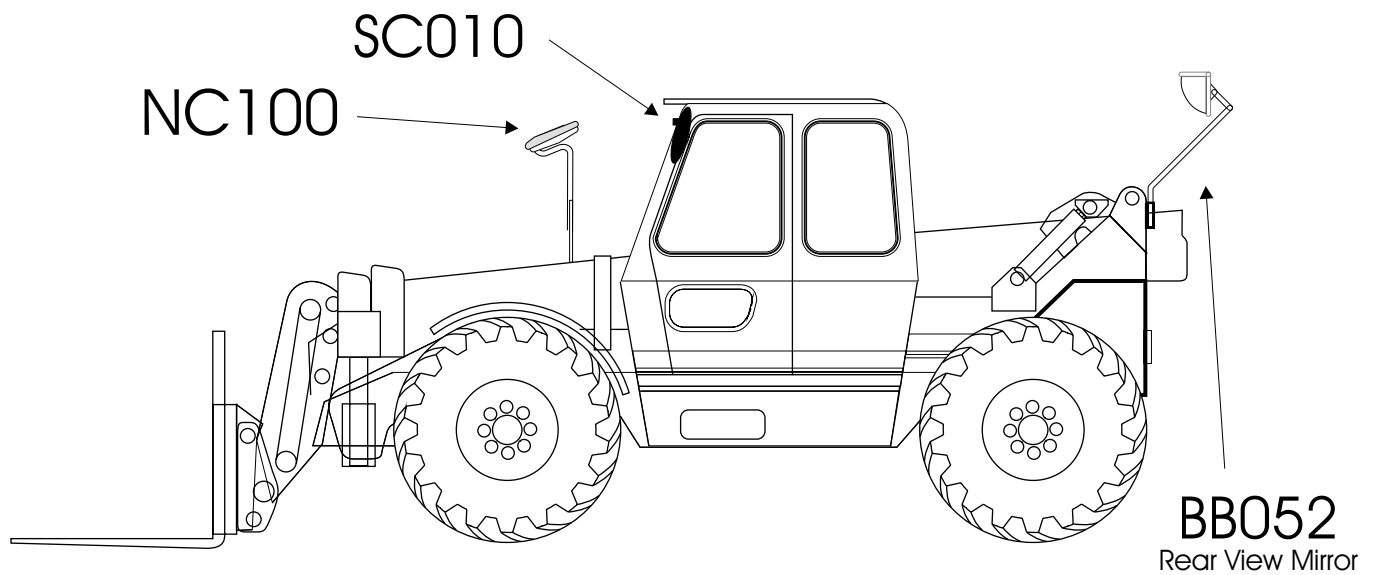

Note.
Hole layout to be drilled
and tapped for BB052
on rear plate or mounting plate
to be welded in position.
SC010 mounts to existing mirror
bracket.
NC100 bracket bolts onto existing
mirror arm. NC100 attaches to arm
using $\frac{3}{4}$ clips.