

Bell B130LC
Bell B210LC
Bell B290LC

Machine Visibility

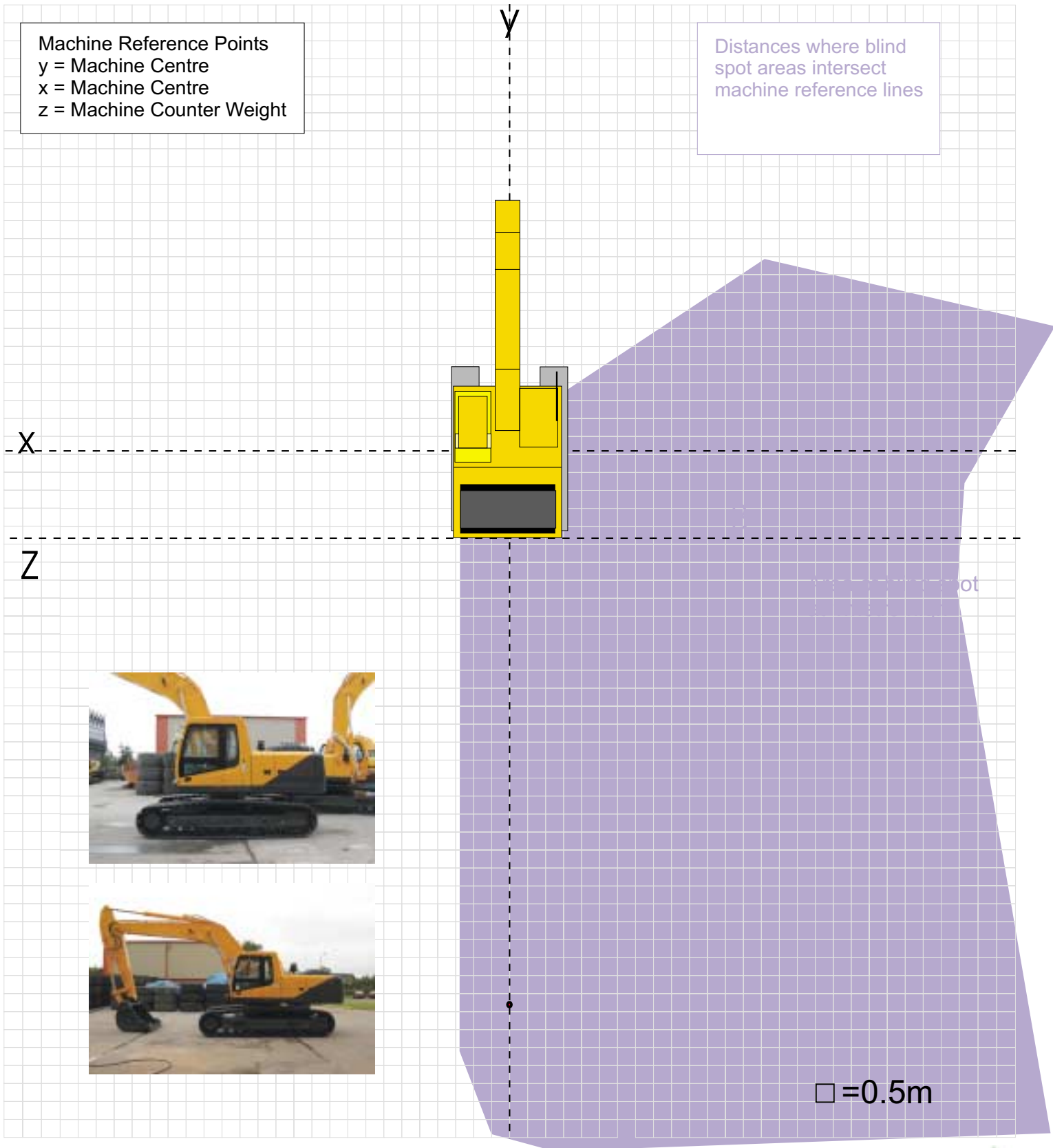

Bell B130LC
 Bell B210LC
 Bell B290LC

Enhanced Visibility

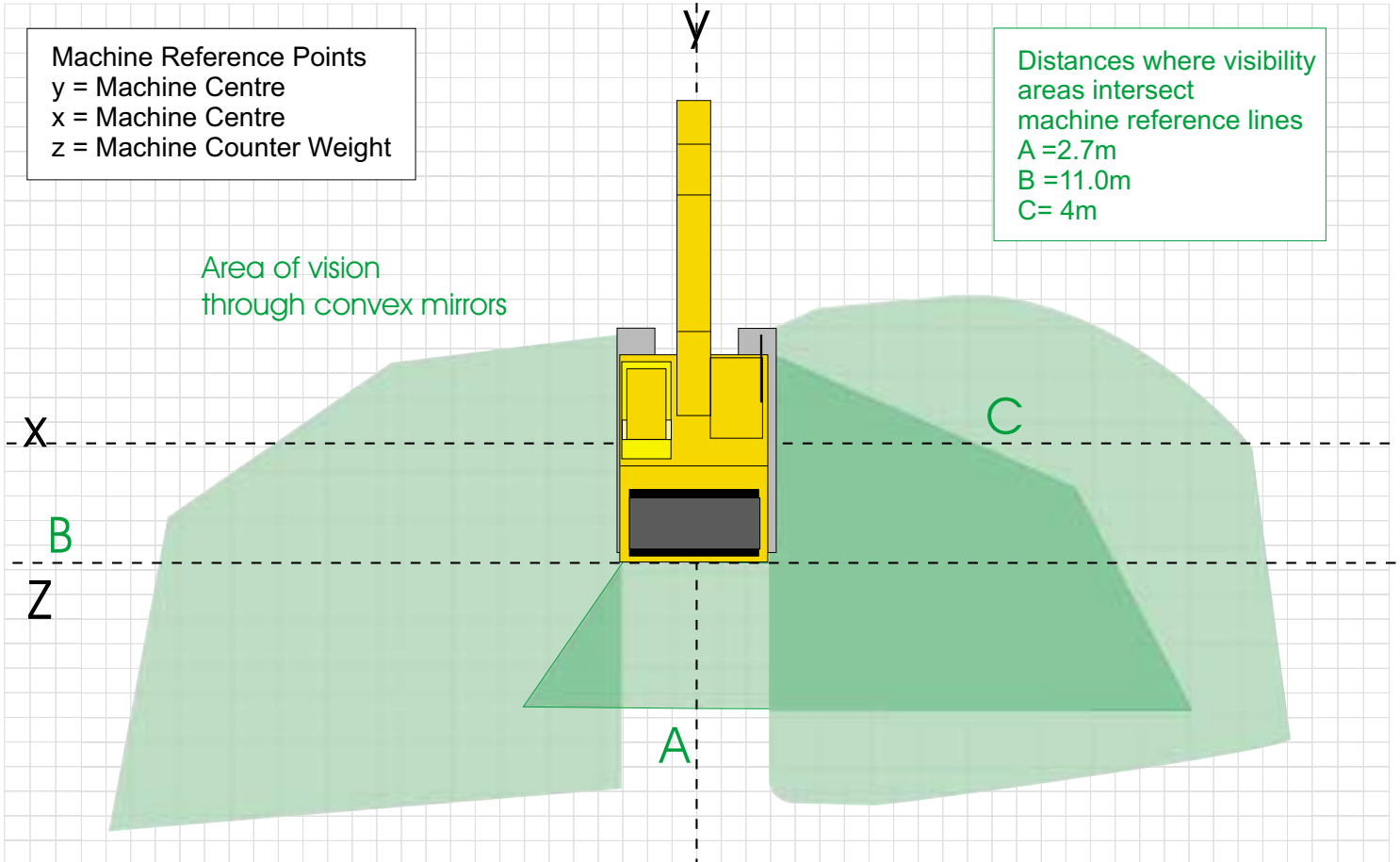

- Requirements**
- 1 x SC010 Drivers Side
 - 1 x BB052UD Counter Weight
 - 1 x M6101 325mm x 195 offside
- Options**
- 1 x NC100 Off Side
 - 1 x Rear View Camera System

□ = 0.5m

